



DGMS - 2

MULTI-STATION (IN-LINE) MANIFOLDS

| KE 7047 | 09/13 |

D_n 04 | p_n 25 MPa

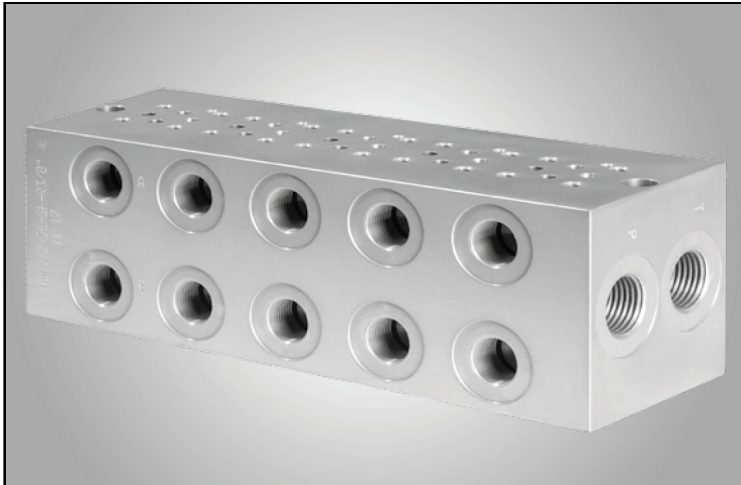

Multistation manifolds DGMS-2 are basic elements for in-line mounting of hydraulic circuits in vertical stacking assemblies

Dn 04, NG 04 | 2-8 sections | Aluminium
EN AW 2007 | Installation dimensions according to:
CETOP RP 121-H (CETOP 2), ISO 4401-02, DIN 24340

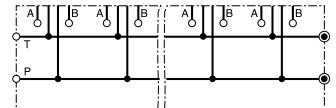

FUNCTIONAL DESCRIPTION

Multi-station manifolds DGMS-2 provides an economical way of building vertical stacked hydraulic circuit using sandwich plate valves in combination with directional valve of size D_n 04. All hydraulic circuits have a common pressure and tank ports (P, T) that are situated on each end of the manifold. Each control circuit has a separate actuator ports (A, B) situated on the frontal area of the manifold.

INSTALLATION, SERVICE AND MAINTENANCE

Multi-station manifolds DGMS-2 can be installed in any working position. Port cavities are designed for pipe or hydraulic hose connection. For cavity dimensions of P, T, A, B ports see the chapter Cavity dimensions of this datasheet. Machined pad must be provided if any section is not used.

DELIVERY

Fittings, machined pads with sealing and mounting screws are not included in the package. These must be ordered separately.

ORDERING CODE

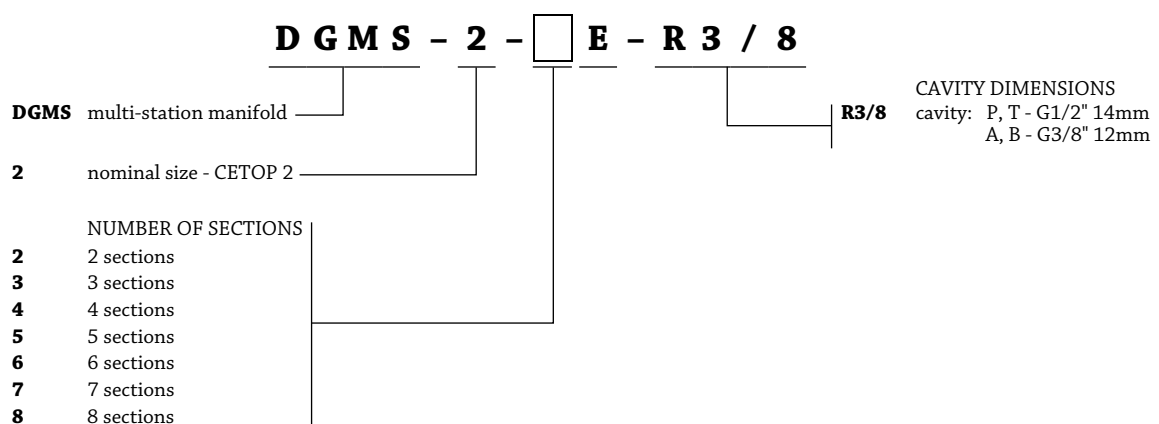

TECHNICAL DATA

	Symbol	Unit	Value
Nominal pressure	P_n	MPa	25
Fluid temperature range	t_{po}	°C	-20 up to +80
Ambient temperature range	t_k	°C	-20 up to +70
Hydraulic medium		Hydraulic oils of power class (HL,HLP) according to DIN 51524	
Weight	m	kg	see Manifold dimensions
Surface treatment		Anodizing	
Material		EN AW 2007	

MANIFOLD DIMENSIONS
DGMS-2-xE-R3/8

x - number of sections (2, 3, 4, 5, 6, 7, 8)

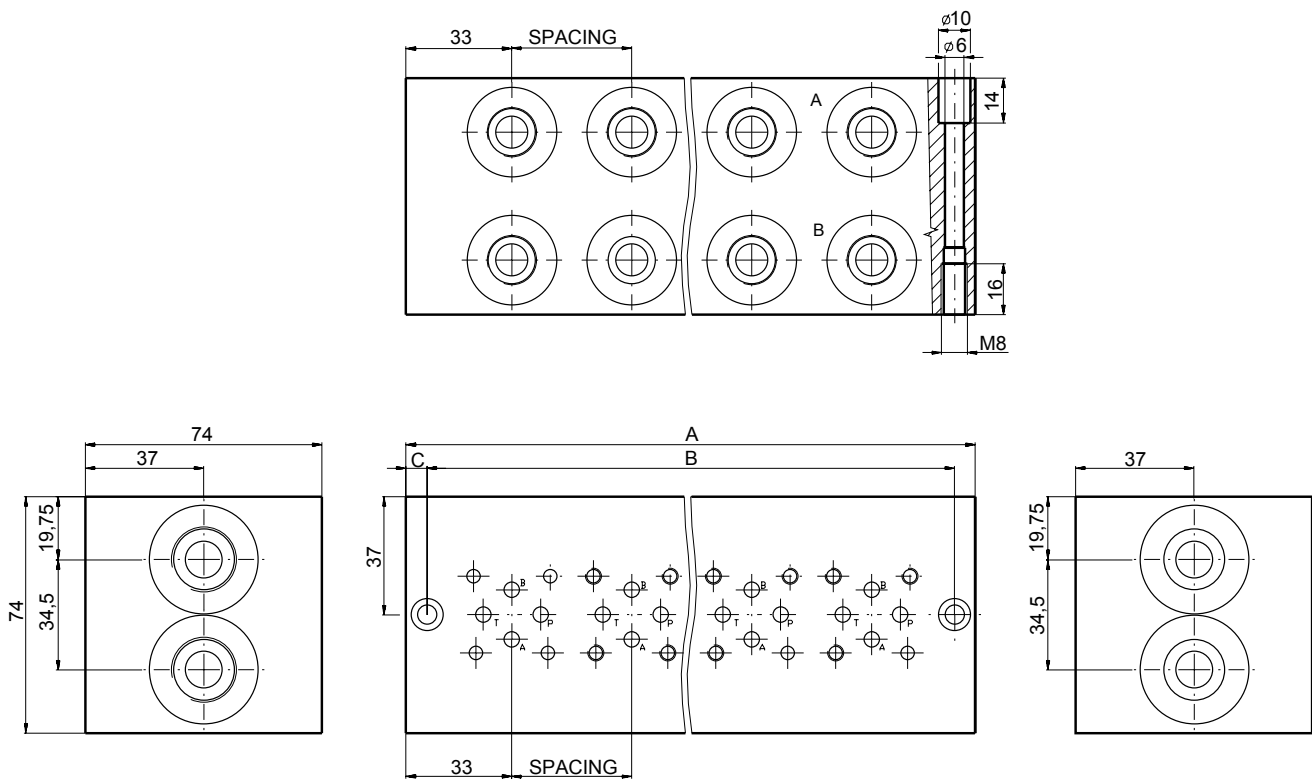

Type	x	A	B	C	Spacing	Weight [kg]
DGMS-2-2E-R3/8	2	102	90	6	37,5	1,3
DGMS-2-3E-R3/8	3	140	126	7	37,5	1,9
DGMS-2-4E-R3/8	4	178	165	6,5	37,5	2,4
DGMS-2-5E-R3/8	5	216	202	7	37,5	2,9
DGMS-2-6E-R3/8	6	254	240	7	37,5	3,5
DGMS-2-7E-R3/8	7	291	278	6,5	37,5	4,1
DGMS-2-8E-R3/8	8	328	315	7	37,5	4,6

CAVITY DIMENSIONS

Cavity	Thread (D)	D2	B1
P,T	G1/2"	34	14
A,B	G3/8"	28	12

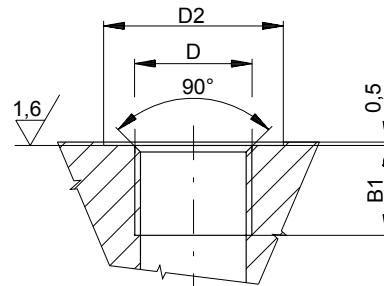

Standard fitting dimensions are used for connecting ports P, T, A, B of the manifold. It is recommended to provide O-ring sealing to all pipe or hydraulic hose fittings.

INSTALLATION DIMENSIONS

According to CETOP RP 121H-R02 (CETOP 2)

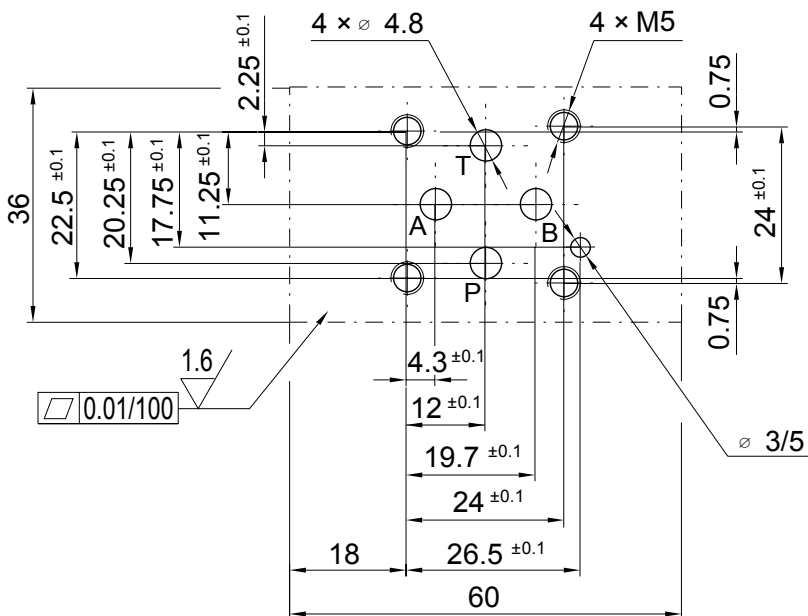



NOTES

Consultancy service is provided by: **PQS Technology, Ltd.**

Sales department: tel.: +420 313 526 236

Technical support: tel.: +420 313 526 378

Fax: +420 313 513 091

www.pqstechnology.co.uk

e-mail: export@pqstechnology.co.uk

e-mail: info@pqstechnology.co.uk

