



RSHP5 - 25

DIRECTIONAL CONTROL VALVES

| KE 2056 | 08/14 |

D_n 25 mm | p_{max} 32 MPa | Q_n 500 dm³/min

Hydraulically or manually operated directional control valves RSHP5-25 are used to control start, stop and direction of flow in hydraulic circuit.

Installation dimensions according to DIN 24 340, ISO 4401, CETOP RP 121H-08 | Manual or hydraulic control | high reliability | any working position

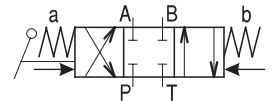
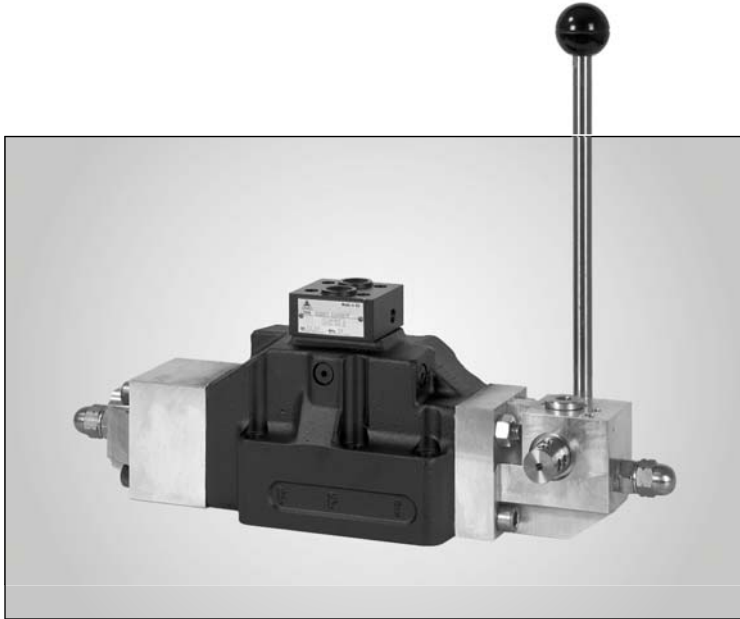

FUNCTIONAL DESCRIPTION

Hydraulically or manually (in case of emergency e.g. pilot valve malfunction) operated directional control valves RSHP5-25 are used to control start, stop and direction of fluid in hydraulic circuit. If the control valves are hydraulically operated the pilot flow can be supplied either through X and Y (bottom side) or through X1 and Y1 (connection plate). The control element that assures main spool movement have to be "Y" type (initial position: A+B → T. For more information about pilot valves see datasheet KE 2020). Design of the spool as well as the spool control provides very sensitive flow control and enables proportional flow control. Reduced stroke of the control spool can be adjusted by stop screws on both sides of the valve. Threaded holes on the flange where the hand lever is located are designed for installation of mechanical hand lever locking device. Flanges are made of aluminium, control elements and stop screws are made either of standard steel (standard environmental resistance) or of stainless steel (enhanced environmental resistance). Valves with enhanced environmental resistance are designed for marine applications (see Ordering code).

ORDERING CODE

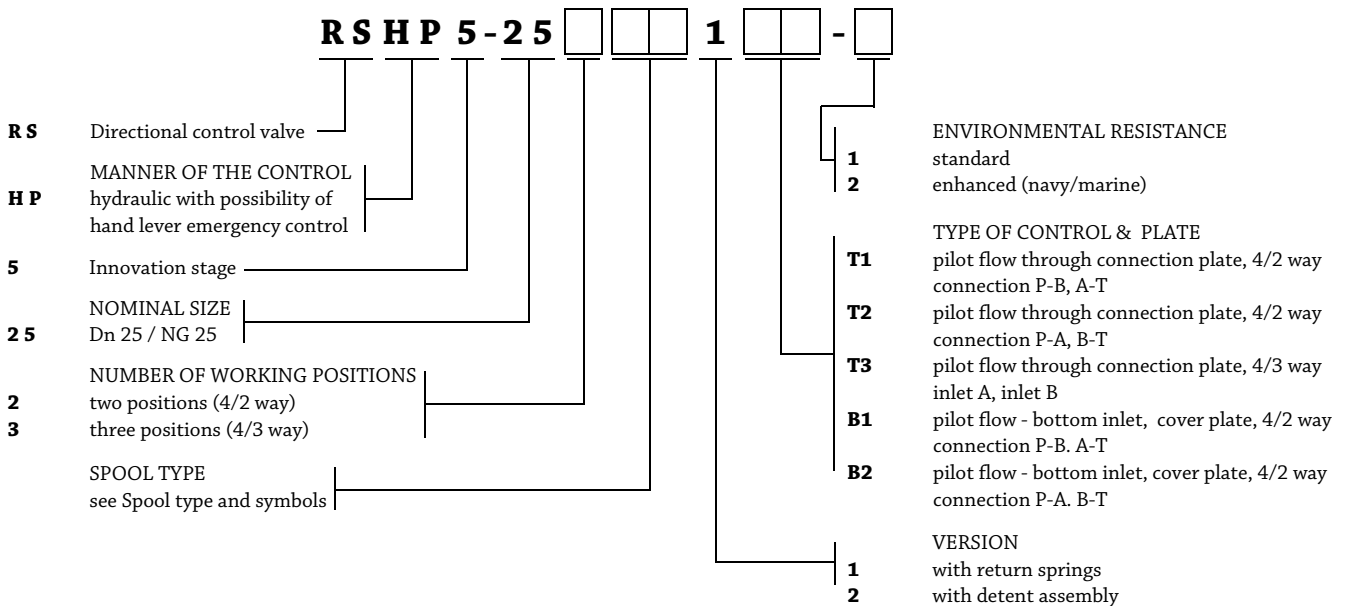

COVER AND CONNECTION PLATES

Directional control valves RSHP5-25 can be operated either using bottom inlets X and Y or connection plate inlets X1 and Y1. If the bottom inlets are used for hydraulic control the valve is equipped with cover plate. Both 4/3 way and 4/2 way directional control valves RSHP5-25 can be controlled using connection plate (inlets X1 and Y1) whereas only 4/2 way valves can be controlled through X and Y inlets. Channel interconnection of the cover plate determines the direction spool movement. Cover plates are manufactured for both direction of spool movement. Two threaded holes (G1/4") on the connection plate enables the pilot flow connection.

Connection plate for
4/3 way valves

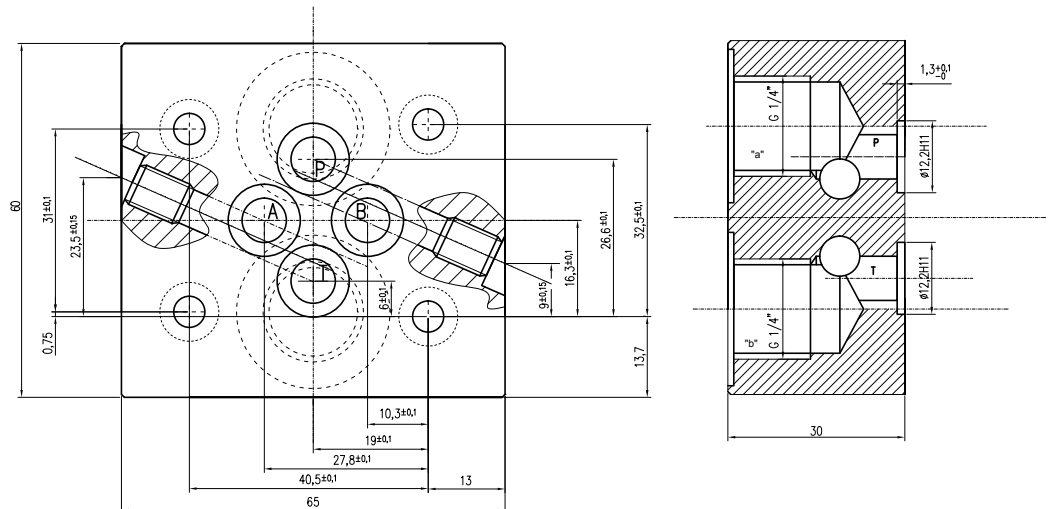

INSTALLATION, SERVICE AND MAINTENANCE

Directional control valves RSHP5-25 are designed for panel installation. They are being mounted by 4 screws M12x80 DIN 912-10.9 with torque 60Nm and can be installed in any working position. The reliability of the valves is conditional upon use of prescribed working fluid, especially its parameters such as cleanness and temperature. It is required that the contact surfaces of the valve must be clear and intact before installation. O-rings must not be disshaped or damaged by any means. Flatness deviation and roughness of the subplate shall not exceed 0,01/100 mm and Ra = 1,6 μm respectively. Directional control valves RSHP5-25 do not require any special maintenance.

DELIVERY

Directional control valves RSHP5-25 are delivered assembled. Spare parts and mounting screws are not included in the package. These must be ordered separately

TECHNICAL DATA

Technical data	Symbol	Unit	Value
Nominal size	Dn	mm	25
Max. flow	Q _{MAX}	dm ³ /min	500
Max. operating pressure in ports P, A, B	p _{MAX}	Mpa	32
Max. operating pressure in port T	p _{MAX,T}	MPa	25
Max. operating pressure in flange chambers	p _{MAX,P}	MPa	10
Min. required pilot pressure	p _{MIN}	MPa	2.5
Pressure drop	Δp	MPa	see Δp = f(Q) curves
Hydraulic fluid	Hydraulic oils of power classes (HL, HLP) according to DIN 51524		
Viscosity range	v	mm ² /s	10 ... 400
Fluid temperature range	t _{PO}	°C	-20...+80
Ambient temperature range	t _A	°C	-20...+60
Maximum degree of fluid contamination	Class 21/18/15 according to ISO 4406 (1999)		
Weight	m	kg	20.5
Mounting position			optional
Hand lever force @ Q = 450dm ³ /min & p = 32MPa *	F _A	N	125
Enclousure type according to EN 60 529			IP65

* the force needed when the valve is manually operated (without presence of pilot flow)

PRESSURE DROP $\Delta p = f(Q)$

Note: measured at $v = 35 \text{ mm}^2/\text{s}$, $T = 50^\circ\text{C}$

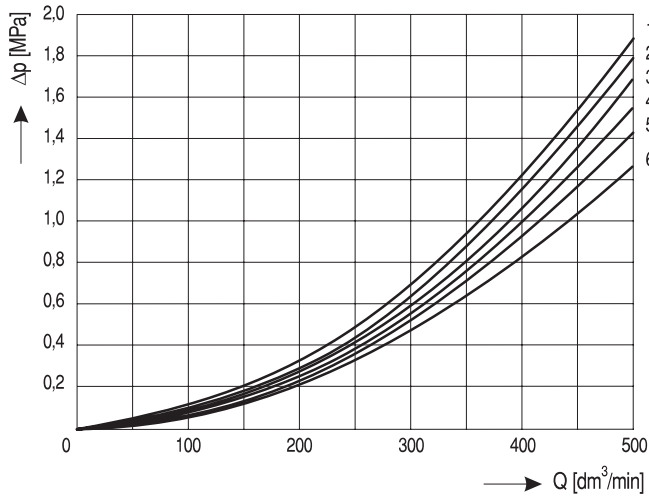

Spool type	Respective pressure drop curve number				
	P - A	P - B	A - T	B - T	P - T
C1	5	5	6	6	1
Y3	3	4	5	6	-
Y5	2	2	6	2	-
Z5	2	3	6	5	-
Z6	6	3	6	2	-

VALVE DIMENSIONS

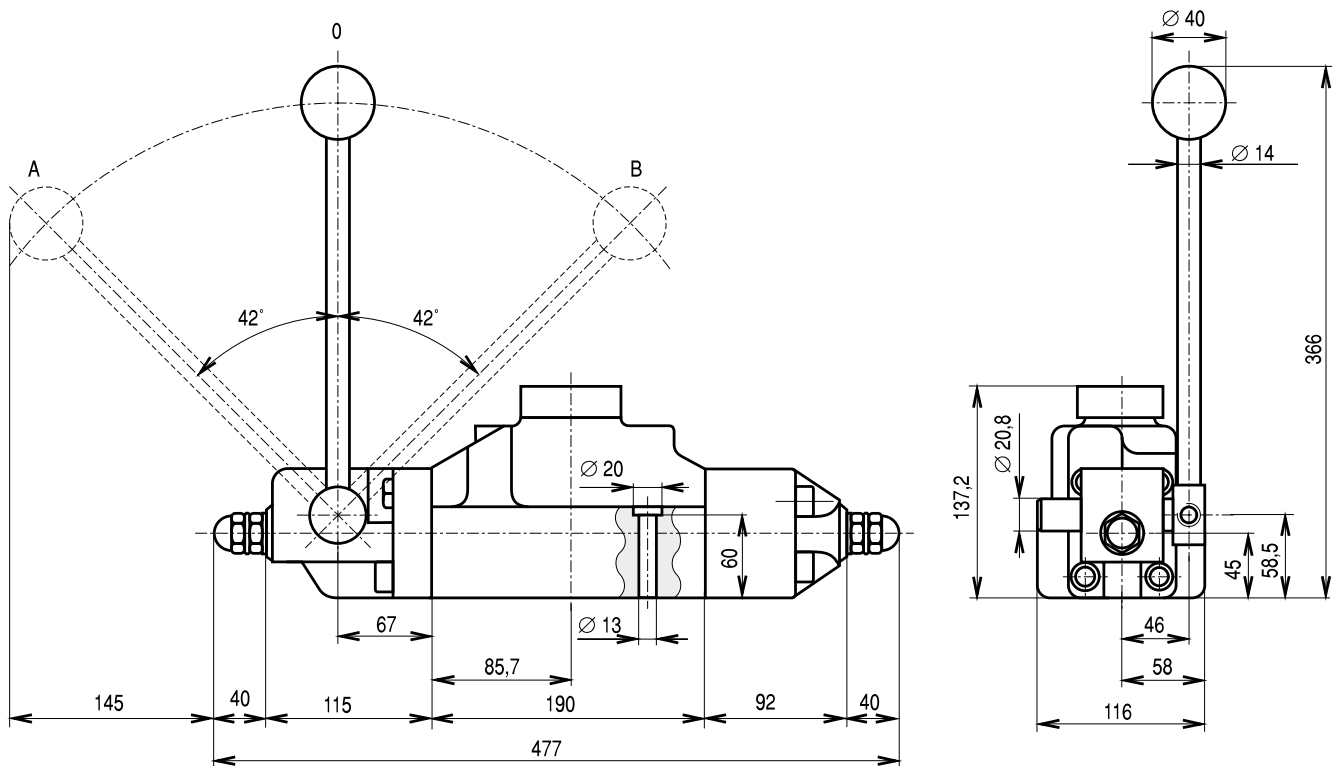

Valve bottom connection surface sealing:

P, A, B, T inlets: O-ring 26.64 x 2.62 mm

X, Y inlets: 20 x 2.65 mm

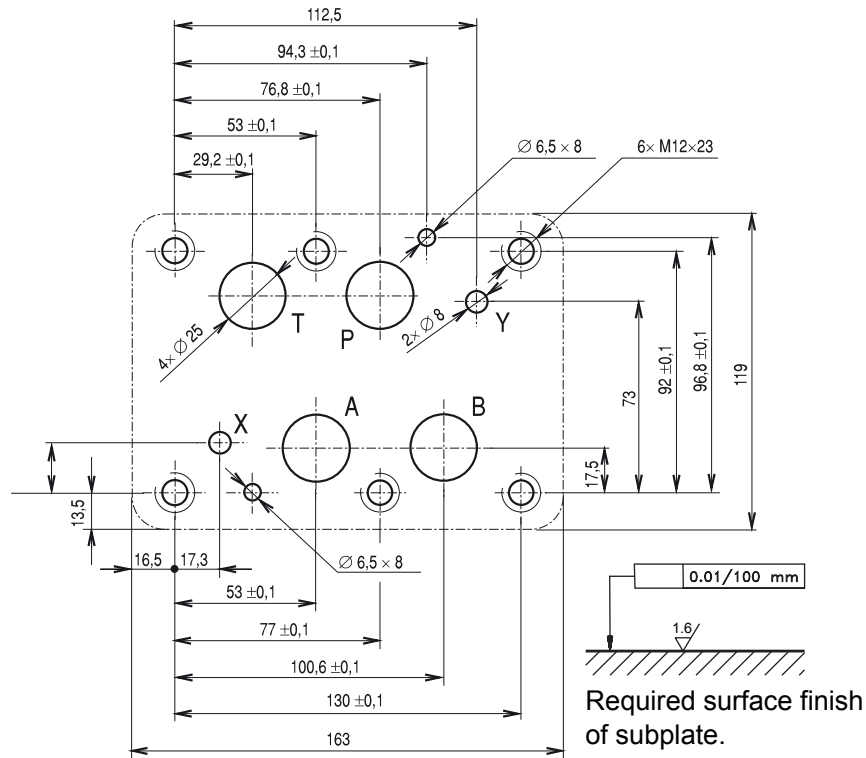
INSTALLATION DIMENSIONS

SPOOL TYPE AND CROSSOVERS

Type	Symbol	Crossover
Y3		
Y5		
C1		
Z5		
Z6		



NOTES

Consultancy service is provided by: **PQS Technology, Ltd.**

Sales department: tel.: +420 313 526 236

Technical support: tel.: +420 313 526 378

Fax: +420 313 513 091

www.pqstechnology.co.uk

e-mail: export@pqstechnology.co.uk

e-mail: info@pqstechnology.co.uk

The data is subject to change. The manufacturer reserves the right to make changes and/or improvements without prior notice. It is understood that the information in this datasheet is being used at one's own risk.

